

Installation Instruction for AF362AC

Mounting Dimension

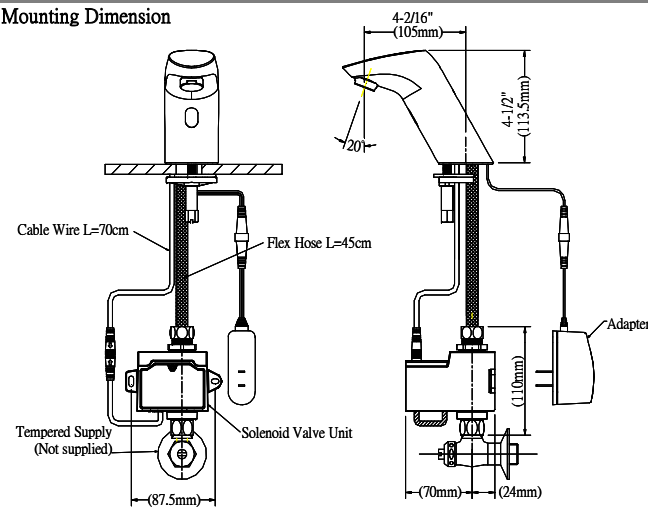

Specification

Model	AF362AC
Product	Electronic Faucet
Material of casing	Chrome Plated Cast Brass
Power supply	AC110V~AC220V 50/60Hz
Power consumption	5W or less
Sensing distance	5-20 cm , Auto sensing
Continuous run	1 minute
Delay time	0.5~1 sec
Applicable water pressure	10-100 PSI
Flowing Volume	8.3 L/min below
Applicable room temperature	39°F~150°F (4°C ~ 65°C)
Ceramic bore diameter	28Φ ~ 35Φ

Operation

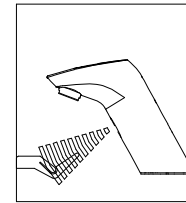

1.The user's hands enter the sensor's range.

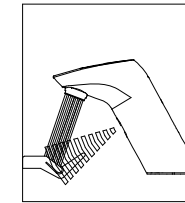

2.The Solenoid Valve activates water flow and will continue until hands are moved away.

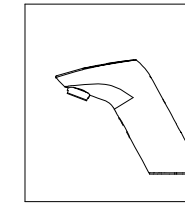

3.After hands are moved away,the faucet automatically shuts off in 1 second.

Caution

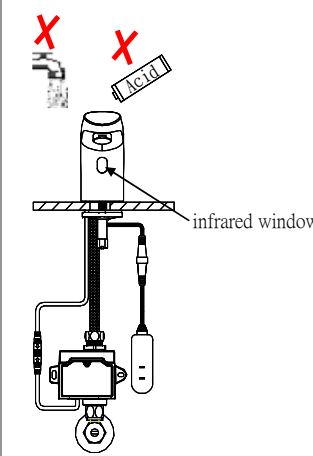

- 1.Keep the infrared window clean at all times. Dirt and dust on the infrared window can cause sensor failure.
2. Do not directly spray water or use strong acids to clean the casing as it may result in short-circuiting. Clean the casing only when necessary.
3. Clean the filter regularly to avoid reduced water flow. This can be done as frequently as once every three months or as long as once every six months,depending on water quality.

Installation Steps

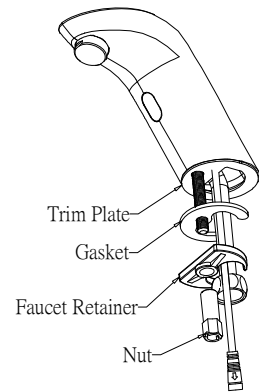

(1) Remove nut, faucet retainer, gasket, But keep Trim Plate

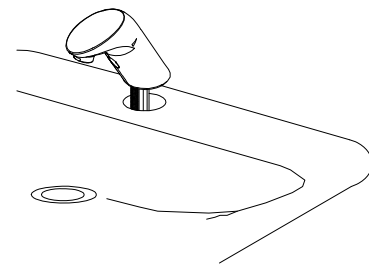

(2) Install Faucet into the center hole of the deck or lavatory.

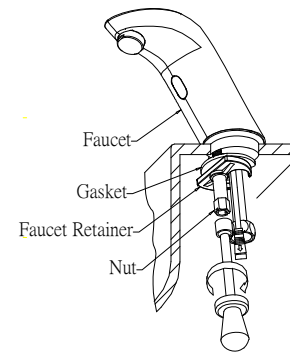

(3) Secure faucet to desk or lavatory with gasket, faucet retainer and nut.

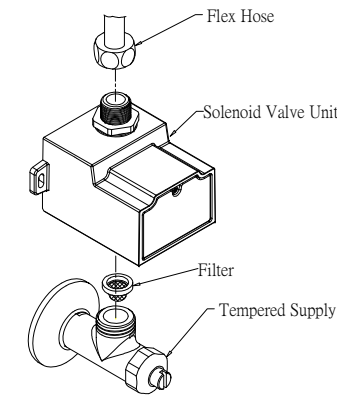

- (4)
- a. Turn on tempered supply to spout out dirty water with miscellaneous article.
 - b. Firmly secure filter and solenoid valve inlet by tools above tempered supply.
 - c. Fasten flex hose onto water outlet of solenoid valve unit.

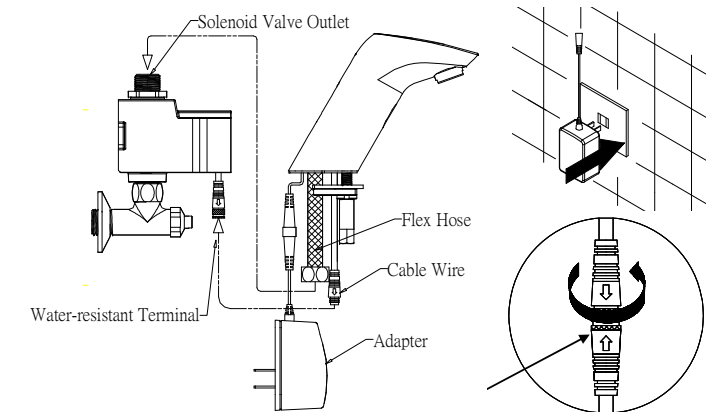

※Caution:Be sure to align both connectors correctly before connecting them. This will keep pins from breaking.

- (5)
- a. Connect water-resistant terminal of sensor module with the solenoid assembly's one and Fasten in a clockwise direction
 - b. Put the adapter plug in the socket of sensor module.
 - c. Confirm no obstacle on basin,deck and faucet's infrared window.
 - d. Connect adapter to power outlet, then the sensor circuit will auto adjust to proper sensing distance according to the various washbowl within three seconds.
 - e. Turn on tempered supply and adjust to proper flow.

Clean filter and water flow Adjustment

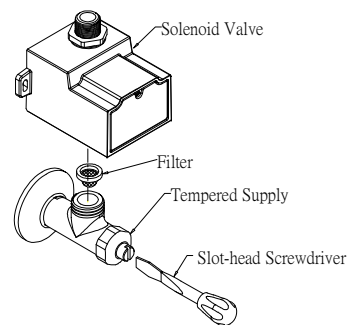

1. Poor water quality may result in reduced water flow. You can prevent this problem from happening by cleaning the filter regularly. To clean the filter, first turn off the water supply. This can be done by using a slot-head screwdriver to turn clockwise and then shut off the water.
2. Now remove the filter, clean it up and place it back.
3. You can also use a slot-head screwdriver to adjust water flow by turning the "Tempered Supply" as shown above.

Sensor range adjustment (automatically adjusted)

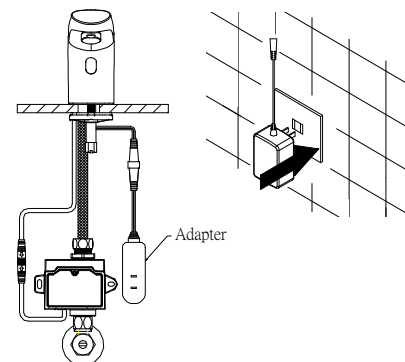

1. Clear up the sink and deck. Be sure no objects are placed in front of the infrared window.
2. Unplug the adapter to release the electricity.
3. After 10 seconds,plug the adapter back in. The next 3 seconds,do not stand near the sink and infrared window while it's automatically adjusting sensor range.

Troubleshooting

Situation	Possible Cause	Solution
No function (LED flashes)	1. dirty infrared window	wipe infrared window with tissues
No function (No LED lighting when using)	1. dirty infrared window	wipe infrared window with tissues
	2. electric power not connected	check for power connection
	3. sensor module failure	replace sensor module
	4. adapter failure	replace adapter
No function (LED keeps blinking when in use)	1. water supply is turned off	check for water supply
	2. solenoid valve connector is loose	reconnect its connector
	3. solenoid valve unit failure	replace solenoid valve unit
	4. sensor module failure	replace sensor module
Water continuously running	1. dirty infrared window	wipe infrared window with tissues
	2. sensor range is too long	re-adjust sensor range
	3. solenoid valve unit failure	replace solenoid valve unit or clean diaphragm
Low flow volume	1. low water supply	increase water supply
	2. filter obstructed	clean filter
	3. aerator obstructed	clean aerator
Water flows when not in use	1. dirty infrared window	wipe infrared window with tissues
	2. sensor range is too long	re-adjust sensor range

Spare parts

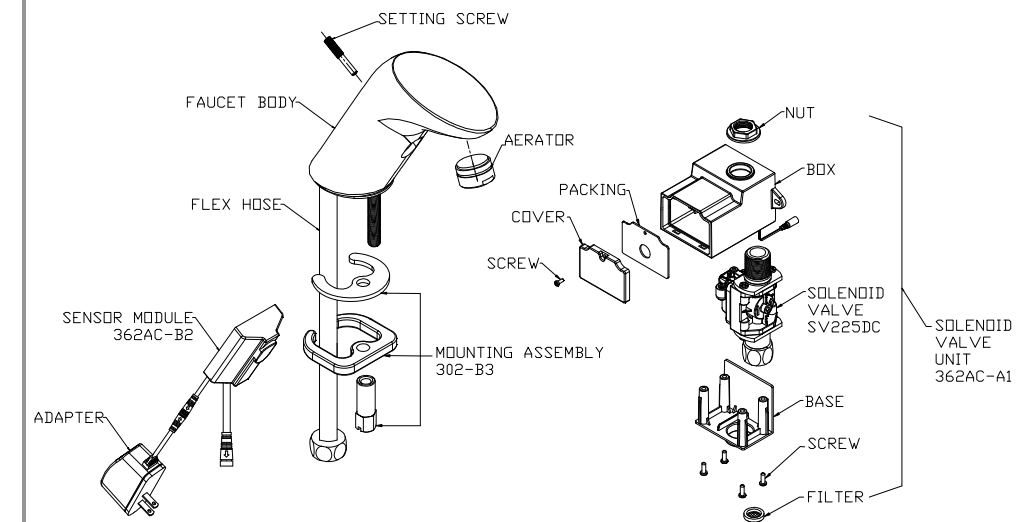

Installation Instruction for AF362DC

Mounting Dimension

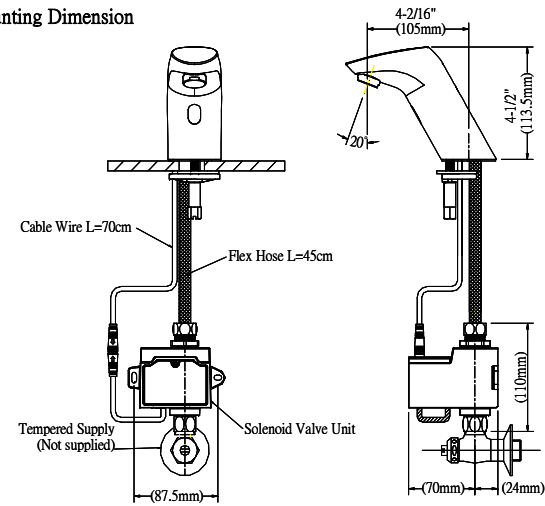

Specification

Model	AF362DC
Product	Electronic Faucet
Material of casing	Chrome Plated Cast Brass
Power supply	Size AA Alkaline battery x 4pcs
Power consumption	2 years (based on 100 person/use/day)
Sensing distance	5-20 cm , Auto adjusting
Continuous run	1 minute
Delay time	0.5~1 sec
Low-power alarm function	Red lamp flashing
Applicable water pressure	10-100 PSI
Flowing Volume	8.3 L/min below
Applicable water temperature	39°F~150°F (4°C ~ 65°C)
Ceramic bore diameter	28 Φ ~ 35 Φ

Operation

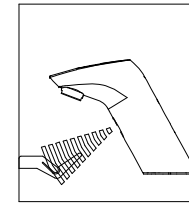

1. The user's hands enter the sensor's range.

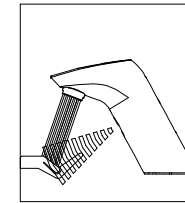

2. The Solenoid Valve activates water flow and will continue until hands are moved away.

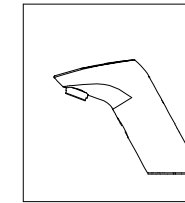

3. After hands are moved away, the faucet automatically shuts off in 1 second.

Caution

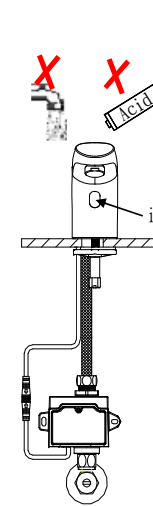

1. Keep the infrared window clean at all times. Dirt and dust on the infrared window can cause sensor failure.
2. Do not directly spray water or use strong acids to clean the casing as it may result in short-circuiting. Clean the casing only when necessary.
3. Clean the filter regularly to avoid reduced water flow. This can be done as frequently as once every three months or as long as once every six months, depending on water quality.
4. The faucet is Alkaline Battery Powered. Replace battery when LED flashes.

Installation Steps

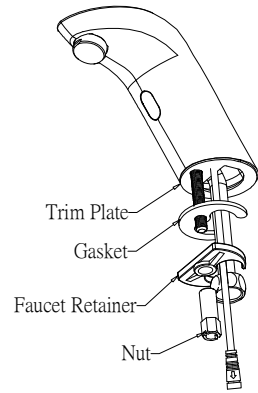

(1) Remove nut, faucet retainer, gasket. But keep trim plate.

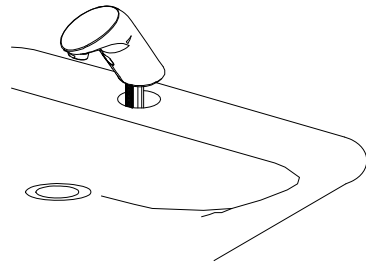

(2) Install faucet into the center hole of the deck or lavatory.

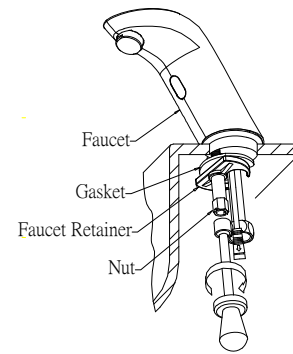

(3) Secure faucet to desk or lavatory with gasket faucet retainer and nut.

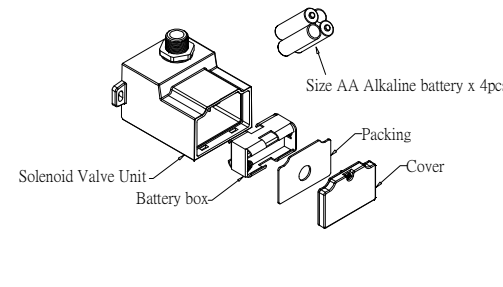

(4) a. Remove the packing and cover of the battery box on solenoid valve unit.
b. Install battery DC1.5V AA x 4 accordingly.
c. Secure the packing and cover back with a screw.

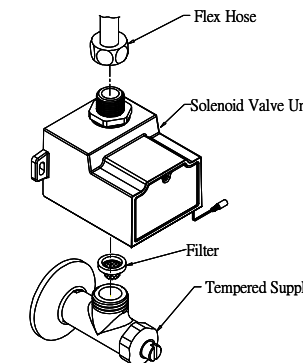

(5) a. Turn on tempered supply to spout out dirty water with miscellaneous article.
b. Firmly secure filter and solenoid valve inlet by tools above tempered supply.
c. Fasten flex hose onto water outlet of solenoid valve unit.

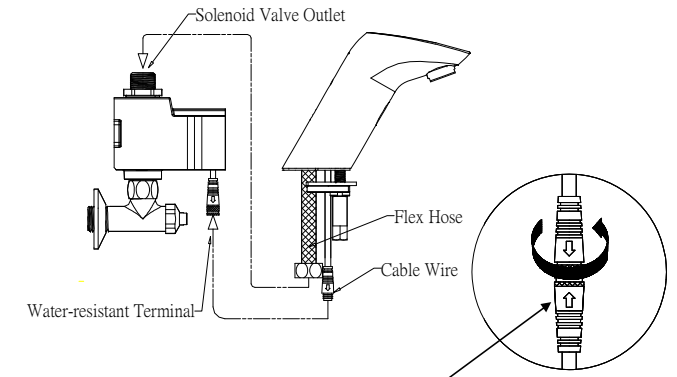

※Warning: It might be broken the pin of connector if wrong plugged-in direction.

(6) a. Confirm no obstacle on basin, deck and faucet's infrared window.
b. Connect water-resistant terminal of sensor module with the solenoid assembly's one and Fasten in a clockwise direction, and do not approach infrared window within 3 seconds to complete faucet electrified and sensory range adjustment.
c. Turn on tempered supply and adjust to proper flow.

Clean filter and water flow Adjustment

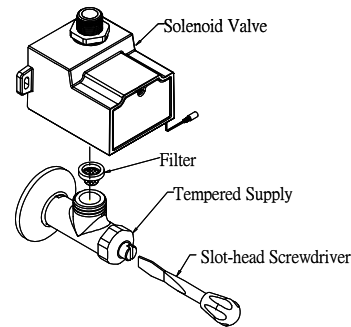

1. Poor water quality may result in reduced water flow. You can prevent this problem from happening by cleaning the filter regularly. To clean the filter, first turn off the water supply. This can be done by using a slot-head screwdriver to turn clockwise and then shut off the water.
2. Now remove the filter, clean it up and place it back.
3. You can also use a slot-head screwdriver to adjust water flow by turning the "Tempered Supply" as shown above.

Sensory range adjustment (automatic adjustment)

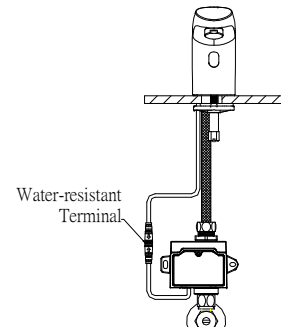

1. Confirm no obstacle on basin, deck and faucet's infrared window.
2. Unplug the water-resistant terminal.
3. Reconnect water-resistant terminal to socket after 2 minutes later, do not approach basin or infrared window, an automatic adjustment of sensory range is completed within 3 seconds.
4. Faucet completely works after turning on tempered supply.

Troubleshooting

Situation	Possible Cause	Solution
No function (LED flashes)	1. dirty sensor window	wipe infrared window with tissues
	2. not connected to power	check power plug or battery terminal
	3. dead battery	replace battery
	4. sensor module failure	replace sensor module
No function (Red lamp flashes on and off during)	1. water faucet not turned on	check for water supply
	2. solenoid valve connector is loose	reconnect its connector
	3. solenoid valve unit failure	replace solenoid valve unit
	4. sensor circuit module	replace sensor module
No function (red lamp flashes)	1. weak battery	replace battery
Water keeps running	1. dirty sensor window	wipe sensor window with tissue paper
	2. solenoid valve failure	replace solenoid valve
Water flow too weak	1. water inflow too weak	adjust valve to increase water flow
	2. filter obstructed	clean filter
Low flow volume	1. less water supply	increase water supply
	2. filter obstructed	clean filter
	3. aerator obstructed	clean aerator
Water flows when not in use	1. dirty infrared window	wipe infrared window by tissues
	2. sensor range is too long	re-adjust sensor range

Spare parts

