

Installation Instruction for AF381AC

Mounting Dimension

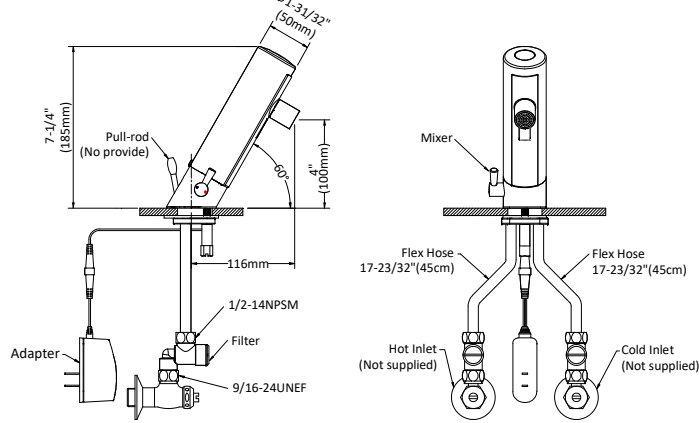

Specification

Model	AF381AC
Product	Electronic Faucet
Material of Casing	Chrome-plated brass casting
Power Apply	AC110V~AC220V 50/60 Hz
Power consumption	5W below
Infrared Sensor Range	Adjusted automatically 5cm~ 15 cm
Protection	Automatic flow stop after 1 minute in case of a continuous abnormal flow
Delay Time	0.5 - 1.0 seconds
Applicable Water Pressure	10-100 PSI
Flowing Volume	3.8L/min below
Applicable Water Temperature	39°F~150°F (4°C ~ 65°C)
Ceramic Bore Diameter	35Φ~ 45Φ (single-hole basin or deck)

Operation

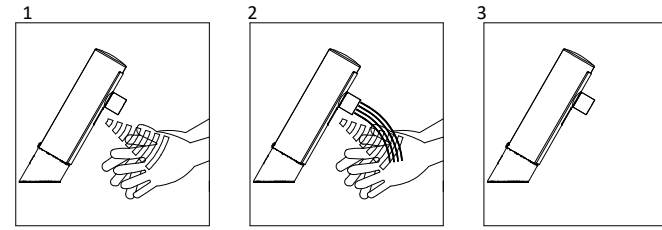

1. Keep hands under faucet for sensor detection.
2. Starts solenoid valve and flows immediately.
3. Stop flowing in 1 second after hands quit.

Caution

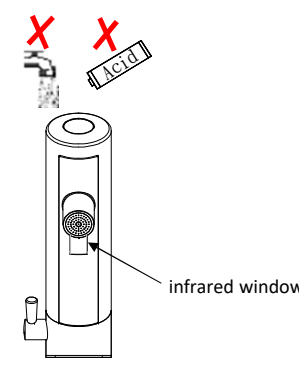

1. In order to avoid sensor failure, keep infrared window always clean to prevent dirt and dust.
2. Do not spray water or wash casing by strong acid, which may cause short-circuit or corrosion on casing. Wipe dirt or stain by wet soft cloth if necessary.
3. Clean filter regularly to avoid flow volume decline. (about 3-6 months depend on water quality condition)

Installation Steps

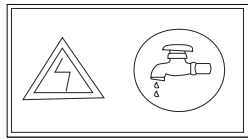

- ※Check electric power and water supply:
- Clean miscellaneous article inside of water pipe to avoid obstruction and faucet failure.
 - Affirm specification of electric power and faucet model to avoid inflammation.

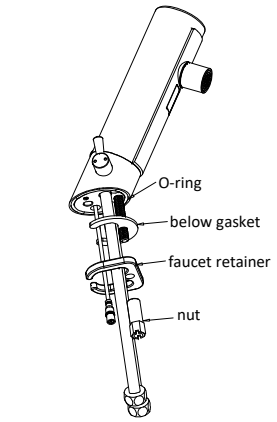

- (1) Remove nut, faucet retainer and below gasket. (keep O-ring)

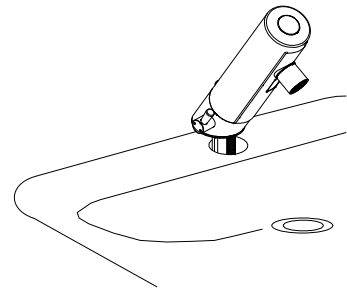

- (2) Secure faucet and O-ring on the upside of lavatory or deck's hole.

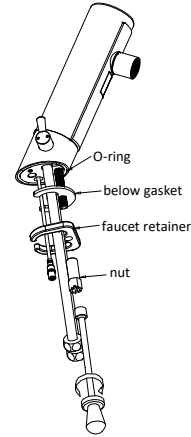

- (3) Firmly secure faucet by tools on lavatory or deck.

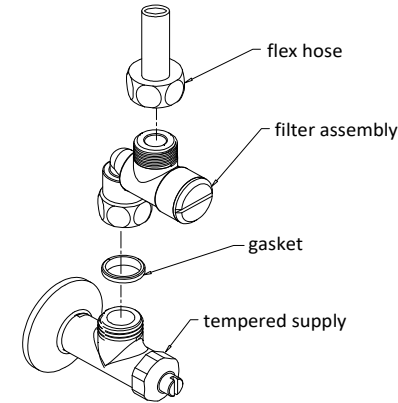

- (4) Turn on tempered supply to spout out dirty water with miscellaneous article.
1. Firmly secure filter assembly by tools above tempered supply.
 2. Fasten flex hose onto outlet of filter assembly.

※Remind to secure filter assembly to avoid faucet's abnormal activation.

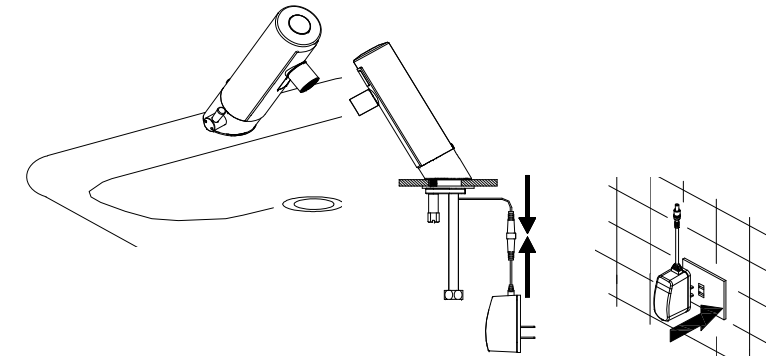

- (5) 1. Make sure there are not any objects in the sensing area, including the sink and counter.
2. plug in the AC/DC adapter, Step out of the sensing range for a minimum of 3 seconds, after which the setting will be completed.
 3. Turn on tempered supply and adjust to proper flow.

Cleaning Filter and Adjusting Water Flow

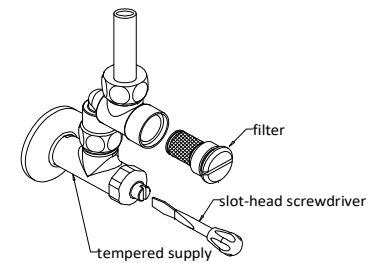

1. Bad water quality resulted filter obstruction and flow decline. Turn off tempered supply by a slot-head screwdriver and take filter out for cleaning.
2. Adjust flow volume by a slot-head screwdriver.

Sensor Range Adjustment (automatically adjusted and set)

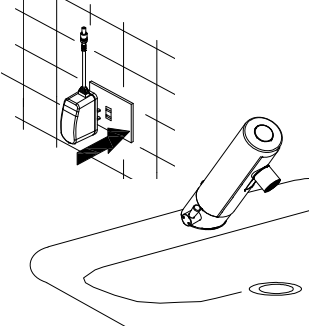

1. Make sure there are not any objects in the sensing area.
2. Unplug the AC adapter and leave it unplugged for at least 1 minute.
3. Plug back in the AC adapter. Step out of the sensing range for a minimum of 3 seconds, after which the setting will be completed.

Temperature adjustment

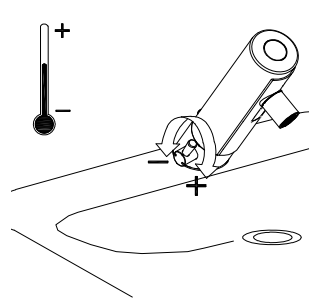

Adjust required temperature by mixer as above chart.

Troubleshooting

Situation	Possible Cause	Solution
No function, LED flashes	1. Dirty Sensor Window	1. Wipe clean infrared window with tissue paper
No function (No LED light when sensing)	1. Loose power connection	1. Check power connection. Make sure it's properly connected
	2. AC/DC adapter failure	2. Replace AC/DC adapter
	3. Circuitry failure	3. Replace circuitry
No function (LED flashes once)	1. Water supply is turned off	1. Check water supply
	2. Loose solenoid valve connection	2. Check solenoid valve connection, reconnect if loose
	3. Solenoid valve failure	3. Replace solenoid valve
	4. Circuitry failure	4. Replace circuitry
Water keeps running	1. Dirty Sensor Window	1. Wipe clean sensor window with tissue paper
	2. Sensing range is set too long	2. Re-set sensing range
	3. Solenoid valve failure	3. Replace solenoid valve
Weak water flow	1. Weak water supply	1. Turn tempered supply to increase water volume
	2. Filtered obstructed	2. Clean filter
	3. Aerator obstructed	3. Clean aerator
Water flows when not in use	1. Dirty sensor window	1. Wipe clean sensor window with tissue paper
	2. Sensing range is set too long	2. Re-set sensing range

Spare parts

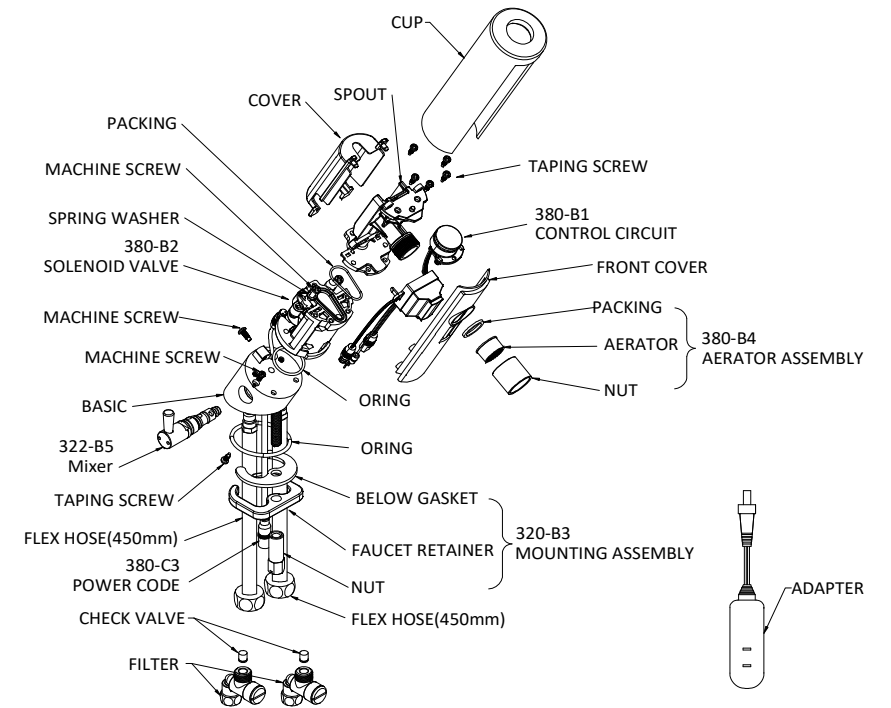

Installation Instruction for AF381DC

Mounting Dimension

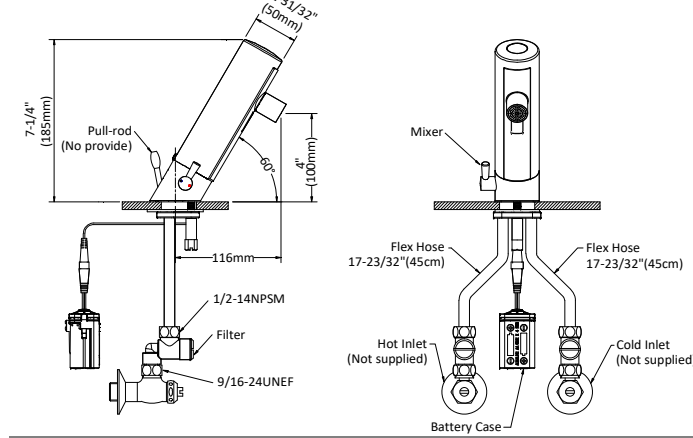

Specification

Model	AF381DC
Product	Electronic Faucet
Material of casing	chrome-plated brass casting
Power Apply	Size AA Alkaline battery x 4pcs
Power Consumption	3W below
Infrared Sensor Range	Adjusted automatically 5cm ~ 15 cm
Protection	Automatic flow stop after 1 minute in case of a continuous abnormal flow
Delay Time	0.5 - 1.0 seconds
Applicable water pressure	10-100 PSI
Flowing volume	3.8L/min below
Applicable water temperature	39°F ~ 150°F (4°C ~ 65°C)
Ceramic Bore Diameter	35Φ ~ 45Φ (single-hole basin or deck)

Operation

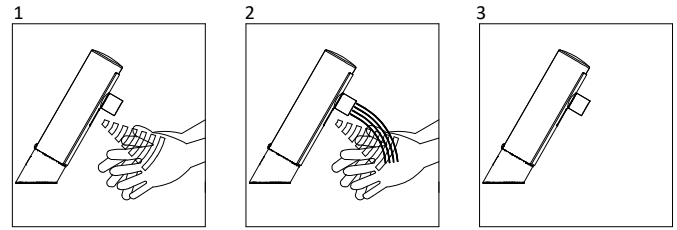

1. Keep hands under faucet for sensor detection.
2. Starts solenoid valve and flows immediately.
3. Stop flowing in 1 second after hands quit.

Caution

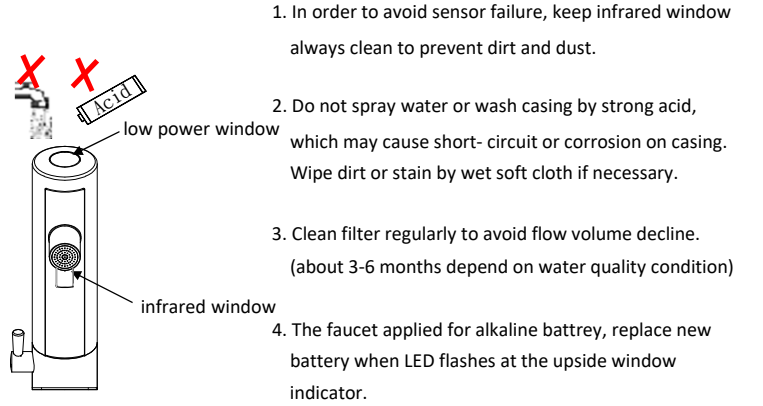

1. In order to avoid sensor failure, keep infrared window always clean to prevent dirt and dust.
2. Do not spray water or wash casing by strong acid, which may cause short-circuit or corrosion on casing. Wipe dirt or stain by wet soft cloth if necessary.
3. Clean filter regularly to avoid flow volume decline. (about 3-6 months depend on water quality condition)
4. The faucet applied for alkaline battery, replace new battery when LED flashes at the upside window indicator.

Installation Steps

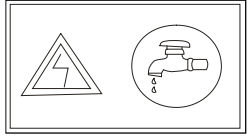

- ※ Check electric power and water source
- Clean miscellaneous article inside of water pipe to avoid obstruction and faucet failure.
- Affirm specification of electric power and faucet model to avoid inflammation.

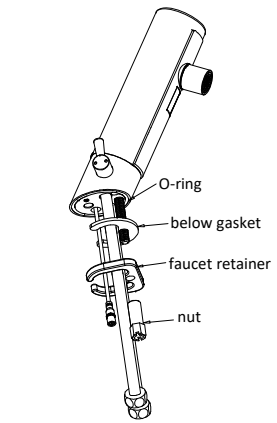

(1) Remove nut, faucet retainer and below gasket. (Keep O-ring)

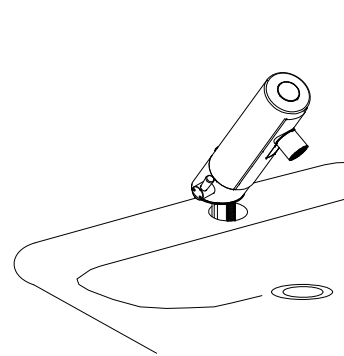

(2) Secure faucet and O-ring on the upside of lavatory or deck's hole.

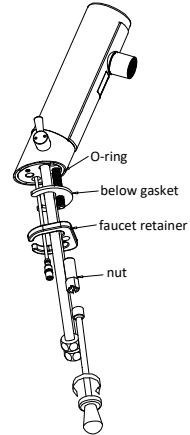

(3) Firmly secure faucet by tools on lavatory or deck.

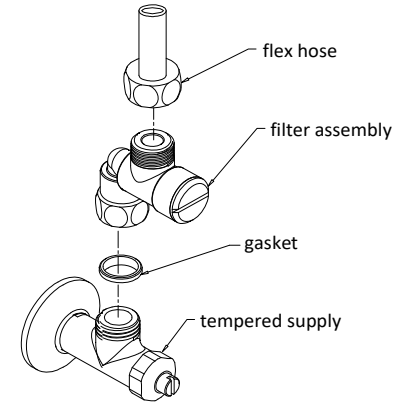

1. Firmly secure filter assembly by tools above tempered supply.
2. Fasten flex hose onto outlet of filter assembly.

※ Remind to secure filter assembly to avoid faucet's abnormal activation.

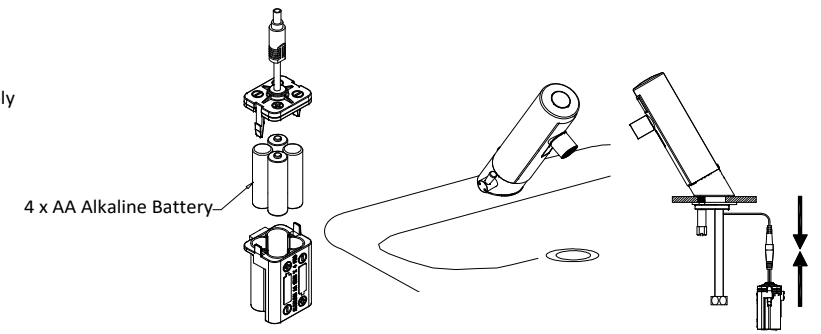

1. Install battery DC1.5V AA x 4 accordingly.
2. Make sure there are not any objects in the sensing area.
3. Connect battery box connector as illustrated. step out of the sensing range for at least 3 seconds, to after which the setting will be completed.
4. Turn on tempered supply and adjust to proper flow.

Clean filter and flow adjustment

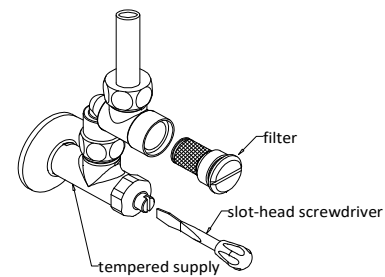

1. Bad water quality resulted filter obstruction and flow decline. Turn off tempered supply by a slot-head screwdriver and take filter out for cleaning.
2. Adjust proper flow by a slot-head screwdriver.

Replacing Battery

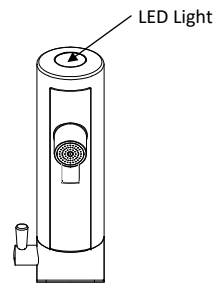

When the LED is flashing red, it is an indication of low battery and need to be replaced immediately.

※ Only Alkaline AA batteries should be used for this product.

Sensor Range Adjustment (automatically adjusted and set)

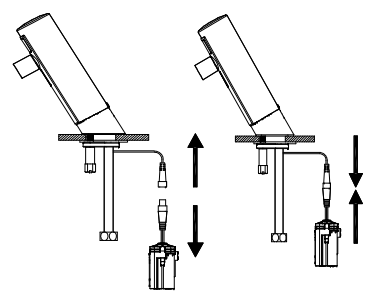

1. Make sure there are not any objects in the sensing area.
2. Unplug the battery box connector and leave it unplugged for at least 1 minute.
3. Connect battery box connector as illustrated. step out of the sensing range for at least 3 seconds, to after which the setting will be completed.

Temperature adjustment

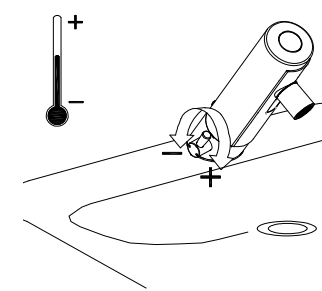

Adjust required temperature by mixer as above chart.

Troubleshooting

Situation	Possible Cause	Solution	
No function, LED flashes	1. Dirty Sensor Window	1. Wipe infrared window clean with tissue paper	
	2. Low (dead) battery	2. Replace battery	
	No function (No LED light when sensing)	1. Dirty Sensor Window	1. Wipe Clean Sensor Window
		2. Loose power connection	2. Check power connection. Make sure it's properly
No function (LED flashes once)	3. Low battery	3. Replace battery	
	4. Circuitry failure	4. Replace circuitry	
	Water keeps running	1. Water supply is turned off	1. Check water supply
		2. Loose solenoid valve connection	2. Check solenoid valve connection, reconnect if loose
3. Solenoid valve failure		3. Replace solenoid valve	
4. Circuitry failure		4. Replace circuitry	
Weak water flow	1. Dirty Sensor Window	1. Wipe clean sensor window with tissue paper	
	2. Sensing range is set too long	2. Re-set sensing range	
	3. Solenoid valve failure	3. Replace solenoid valve	
Water flows when not in use	1. Weak water supply	1. Turn tempered supply to increase water volume	
	2. Filtered obstructed	2. Clean filter	
	3. Aerator obstructed	3. Clean aerator	
Water flows when not in use	1. Dirty sensor window	1. Wipe clean sensor window with tissue paper	
	2. Sensing range is set too long	2. Re-set sensing range	

Spare parts

