

# CF107 Smart Toilet Installation Instructions

## Table of Contents

---

Product Display .....	P1
Inside Parts .....	P1
Product Features .....	P2
Specification .....	P2
Parts List .....	P3
Operation .....	P4
Care and Cleaning Instructions .....	P4
Installation Instructions .....	P5
Function Test and Adjustment .....	P9
Cautions .....	P10
Troubleshooting .....	P11
Sensor Unit Mounting – Double-Sided Tape Option	P12

# CF107 Smart Toilet Installation Instructions

## ■ Product Display



## ■ Inside Parts

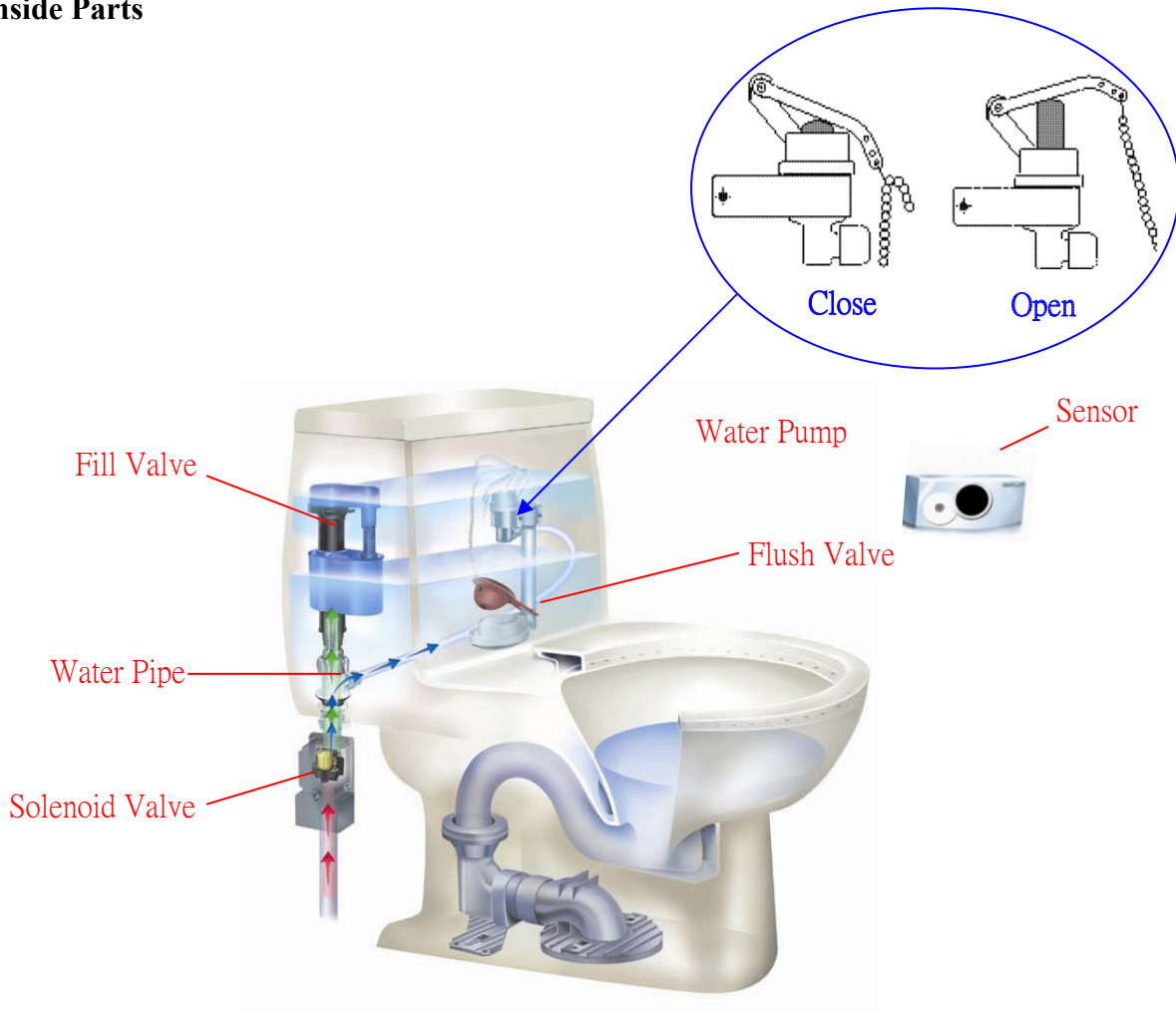







## ■ Features

- . The infrared sensor allows hands-free flushing, ensuring hygiene and a bacteria-free environment.
- . Automatic hands-free flushing function is especially beneficial to the handicapped, elderly, infirmed and young children.
- . The sensor is powered by 4 AA batteries so there is no need for a wall outlet. It is not limited by any voltage requirements and there is no danger of electric shock. Under normal operating conditions battery life goes beyond 1 year
- . Designed without using any electronic parts or electric wiring inside the tank. It also means less problems and a longer life for every Smart Toilet.
- . Wireless sensor. Easy installation.
- . Flexible installation fits most tank designs. It can be used with mid to standard height water tanks and all standard toilet bowls. It can be installed on new WCs or it can be used to upgrade existing WCs.
- . Can be used both for commercial and residential restrooms.

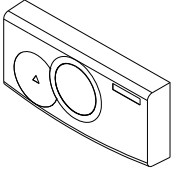
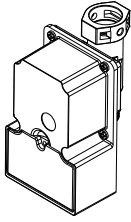
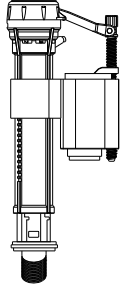
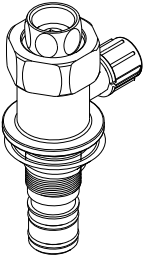
## ■ Specifications

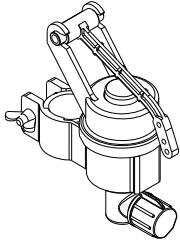
Power Supply	
Sensor Unit	4 Alkaline Type AA Batteries
Solenoid Valve Assembly	4 Alkaline Type AA Batteries
BatteryLife	2 plus year(100 flushes/day )
Power Consumption	3W or less
Low Battery Warning	Flashes on LED
SensorType	Infrared
RemoteType	RF Wireless Remote Control(315MHz)
Sensor Range	5 ~ 10 cm
Flush Time	Adjustable
Flush Volume	6 ~ 9 liter( adjustable)
Mechanical Life	Over 500,000 flushes
Water Inlet Pipe Bore	PF1/2
Applicable Water Pressure	0.5 ~ 6kgf/cm <sup>2</sup>
Applicable Tanks	mid to standard height water tank with flush handle installed on the front

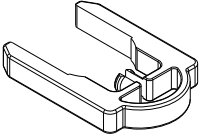
■ Parts List

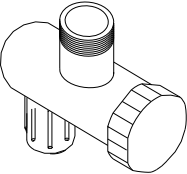
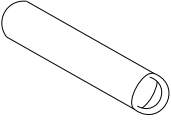
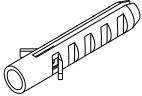
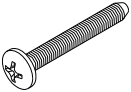
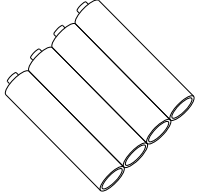
		
<p>Sensor Unit /Qty(1)</p>	<p>Solenoid Valve Unit /Qty(1)</p>	<p>Fill Valve Unit/Qty(1)</p>
		
<p>Water Connector/Qty(1)</p>	<p>PVC Tube/Qty(1)</p>	<p>Water Pump Unit/Qty(1)</p>
		
<p>Flexible Tube/Qty(1)</p>	<p>Peg/Qty(1)</p>	<p>Link Chain &amp; Clips/Qty(1)</p>
		
<p>Filter Unit/Qty(1)</p>	<p>Code-Matching Tool/Qty(1)</p>	<p>Anchors/Qty(2)</p>
		
<p>Screws/Qty(2)</p>	<p>Alkaline Type AA Batteries/Qty(8)</p>	

## ■ Operation

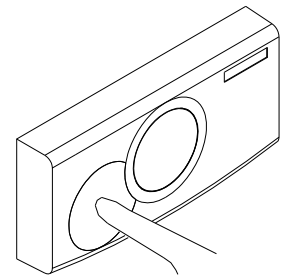
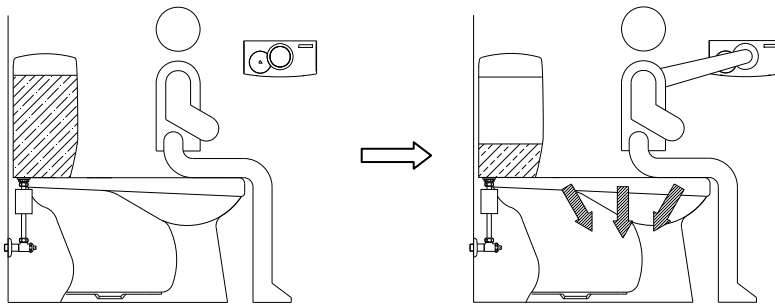

- . When the user's hand approach the detection zone, the sensor sends a signal to activate the solenoid valve which lifts the flapper and flushes the toilet.
- . Electronic manual button gives users the option of flushing the toilet by simply pressing the button.

## ■ Care and Cleaning Instructions

1. Keep the display panel clean at all times to prevent sensor function failure.
2. Do not place heavy objects or cigarette butts on the casing.
3. Do not spray water or wash the casing with highly concentrated chemical cleaners. This may result in short-circuiting or corrosion. Use mild soap and water, then wipe dry with a soft clean cloth after washing.

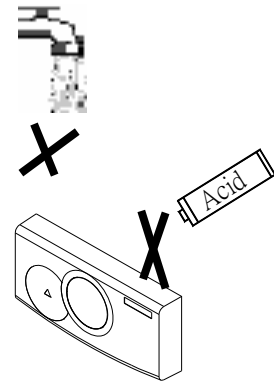

### 4. Clean Filter Screen:

Poor water quality will result in obstructed and reduced water flow.  
To clean the filter screen do the following:

1. Turn off water supply.
2. Remove the filter screen.
3. Wash the screen with clean water and re-insert.

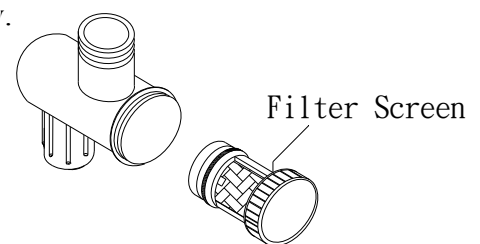

### 5. Replace Batteries

Need to replace batteries when

- 1 The red light on the sensor unit flashes
- 2 The solenoid valve "BEEPS" continuously.

Note: Replace with four AA batteries for either sensor unit or solenoid valve assembly

Red light flashes

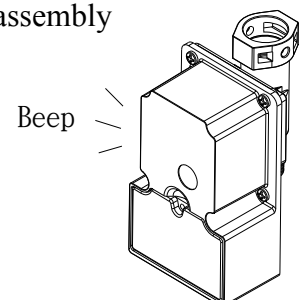
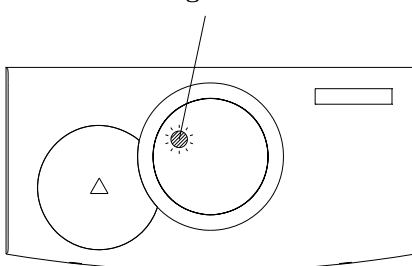

## ■ Installation Instructions

1. Close control stop. See Figure (1).

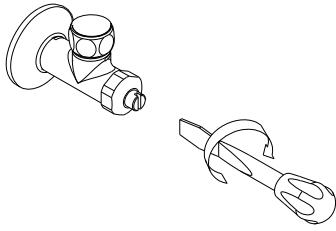
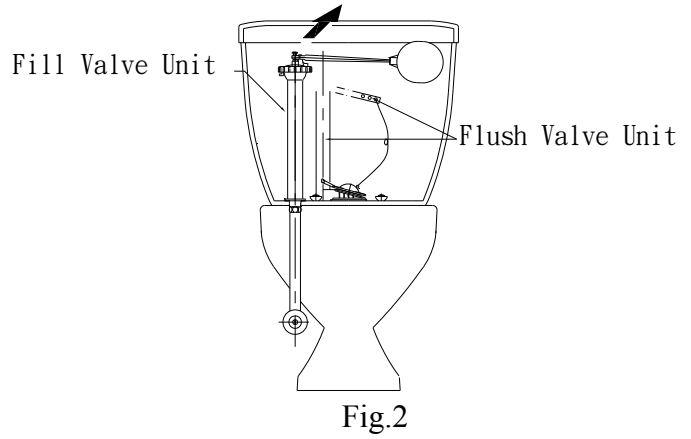

Fig.1



2. Remove the fill valve unit and its connecting pipe. See Figure(2).  
(The flush valve unit remains in place)

3. Install the filter unit to the control stop. See Figure(3).

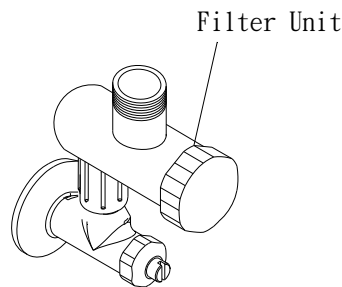

Fig.3

4. Assemble the fill valve unit and water connector as illustrated in Figure(4).

5. Lock the PVC tube to the water connector with a nut provided. See Figure(4)

6. Install the fill valve unit in the tank as illustrated in Figure(5). Secure it with a nut provided.

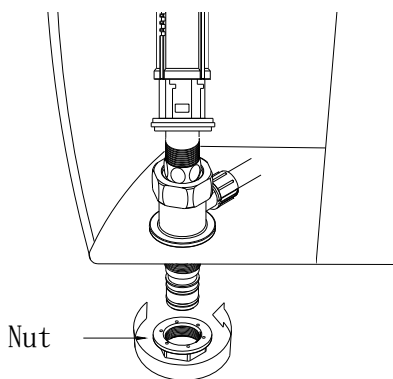

Fig.5

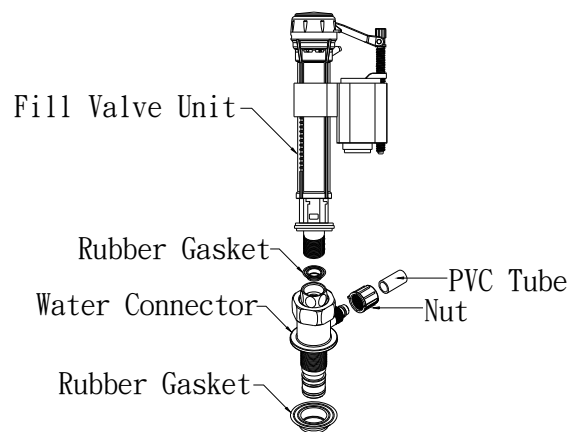
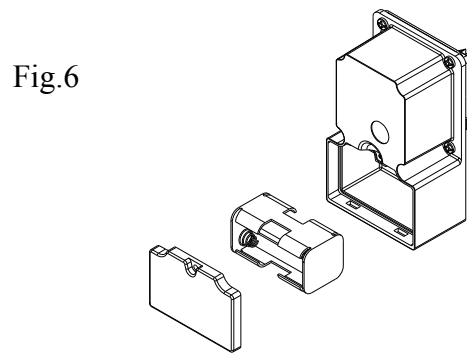

Fig.4

7. Remove the cover of the battery case on solenoid valve assembly as illustrated in Figure(6).  
Install 4 Alkaline Type AA batteries. Secure the cover back with a screw.



8. Install the flexible tube into the solenoid valve unit. See Figure(7)  
Install the combined parts into the water connector. See Figure(8)

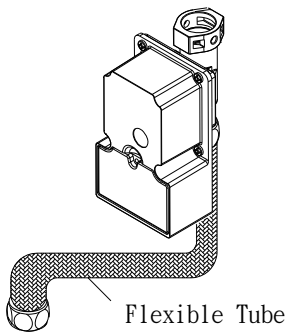
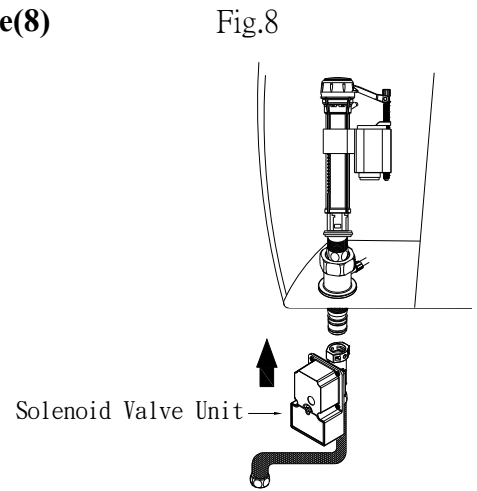
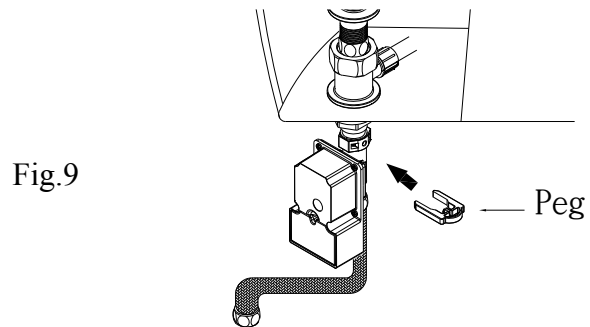

Fig.7



9. When positioned properly, secure it with the peg. See Figure(9)



10. Install the flexible tube to the filter unit. (DO NOT bend the tube.) See Figure(10)

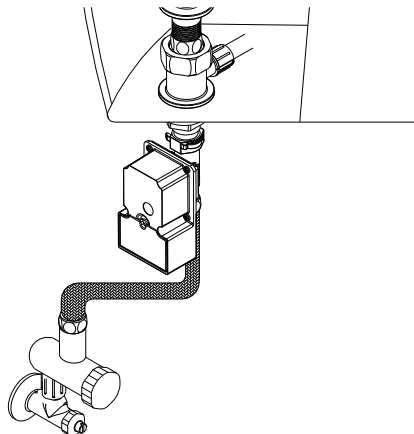
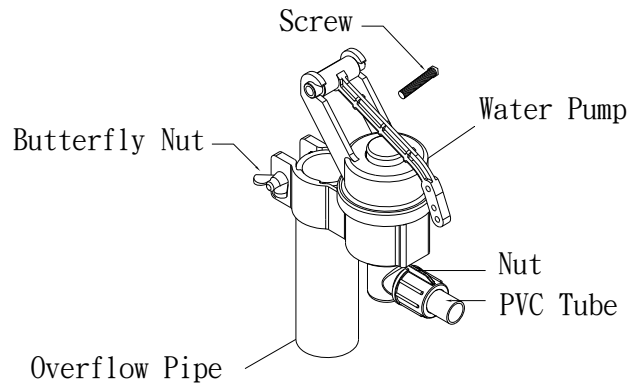

Fig.10

**11. Install water pump to the top end of the flush valve . Adjust to a proper height then tighten with a butterfly nut. See Figure(11)**

Fig.11



**12. Insert the PVC tube to the water inlet of the water pump unit. Secure it with a nut. See Figure(11.12)**

Fig.12

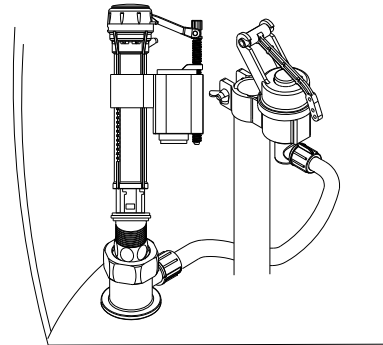

**13. Install the link chain as illustrated in Figure(13 )**

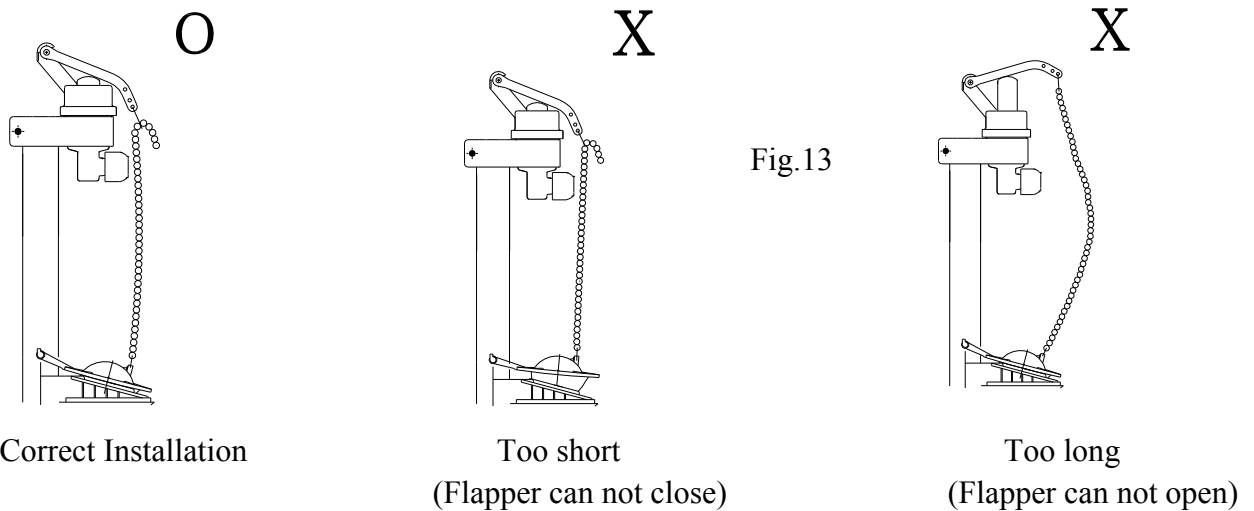

**14. Remove the cover of the battery case on the back of the sensor unit. Install 4 Alkaline Type AA batteries. Secure the cover back with screws. See Figure(14)**

Fig.14

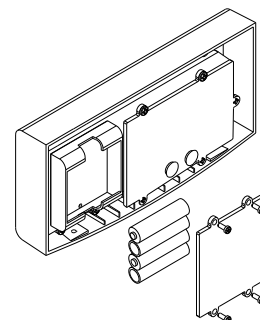



**15. Mount sensor unit onto the wall as illustrated in Figure(15)(16).Locate it on the side wall.  
(See P.11 for instructions when using double sided tape for installation.)**

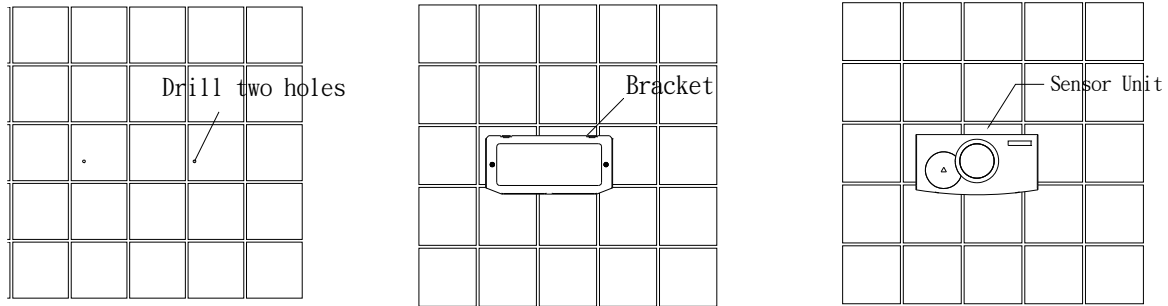

Fig.15

**Screw and Anchor Option.** See Figure(15)

- Using a 1/4” drill bit, drill two holes in their proper positions.
- Install the bracket on the wall. Secure with anchors and screws.(included)
- Insert the sensor unit onto the bracket.(Place the sensor unit at the bottom of the bracket and slightly push to fit in the bracket.) Secure it with two screws on the bottom of the sensor unit.

**To locate correct position for sensor unit on side wall.See Figure (16).**

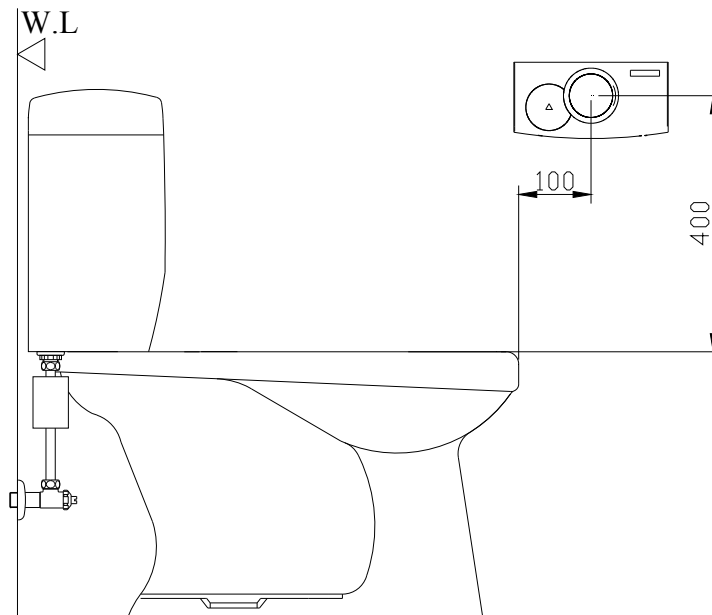
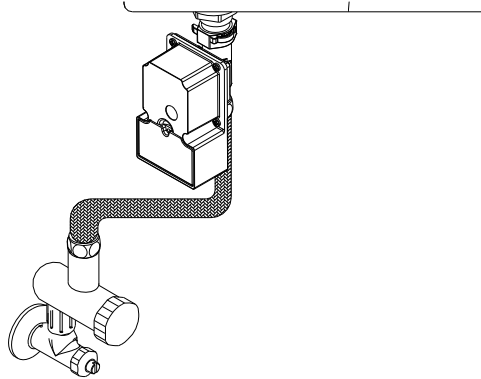

Fig.16

Unit: mm

## ■ Tests and Adjustments

1. Open control stop when finished installation. Turn on the water. As the water fills in the tank. Check the connecting points. Make certain no leaking occurs.



2. Observe water as it fills the tank. Make certain the water stops when it reaches the preset water level. ( Make sure no leaking occurs.) The flush volume varies depending on the level of water. Adjust the water level with the switch on top of the fill valve unit. Clockwise to increase the level. Counterclockwise to decrease the level. ( Adjust only if necessary.)

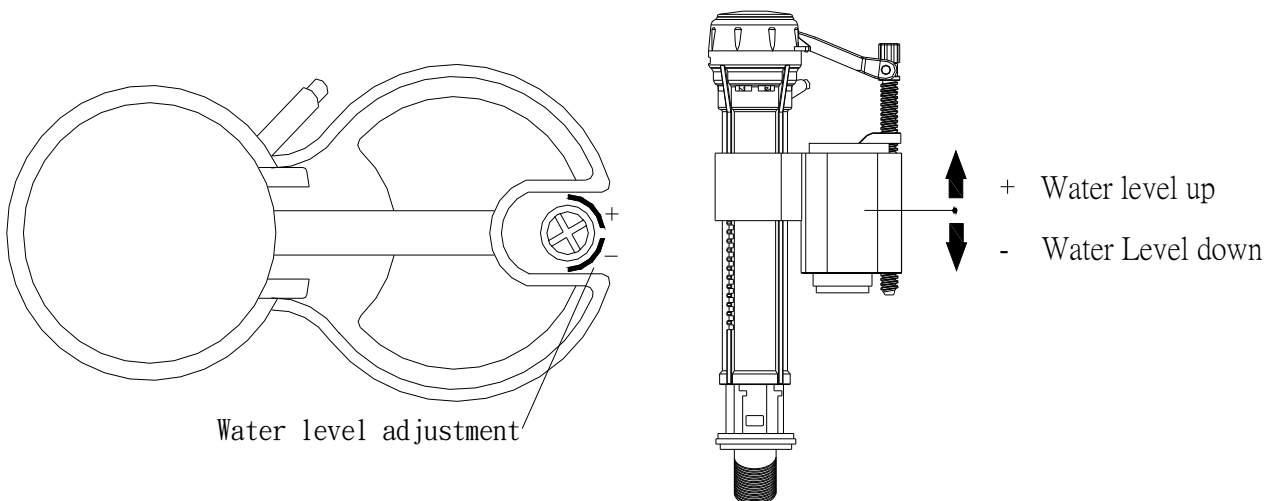

3. For courtesy flush, press the manual button on the sensor unit. When the sensor senses a user in the detection zone for 5 seconds, the sensor sends a signal to the Solenoid Valve to automatically operate flushing after the user leaves the detection zone. Make sure the arm of the water pump doesn't touch the tank lid when it's rising.( See the instructions on step 11) Also, make certain the remaining manual flush handle works properly and no interference occurs among the parts inside the tank while operating the flushing mechanism.

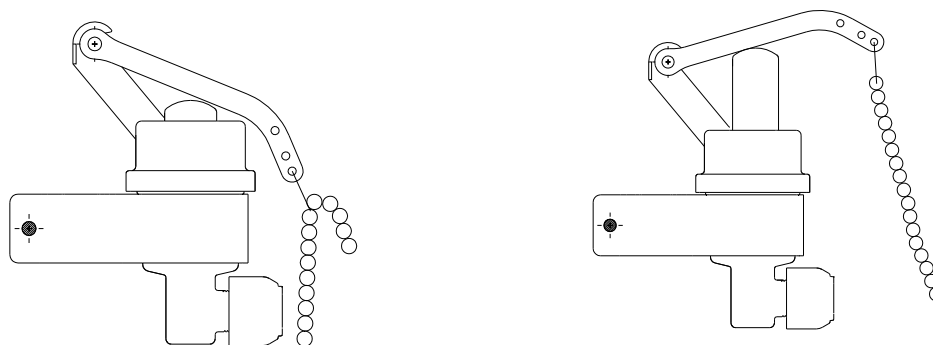

#### 4. Adjust flushing time:

Since the closet is Incomplete flushing , please refer to the chart to adjust the appropriate flush time and obtain an optimum flushing effect. **(Adjust only if necessary)**

SW1	SW2	SW3	FLUSH TIME
OFF	OFF	OFF	1 SEC
OFF	OFF	ON	2 SEC
OFF	ON	OFF	3 SEC
OFF	ON	ON	4 SEC
ON	OFF	OFF	5 SEC
ON	OFF	ON	6 SEC
ON	ON	OFF	7 SEC
ON	ON	ON	8 SEC

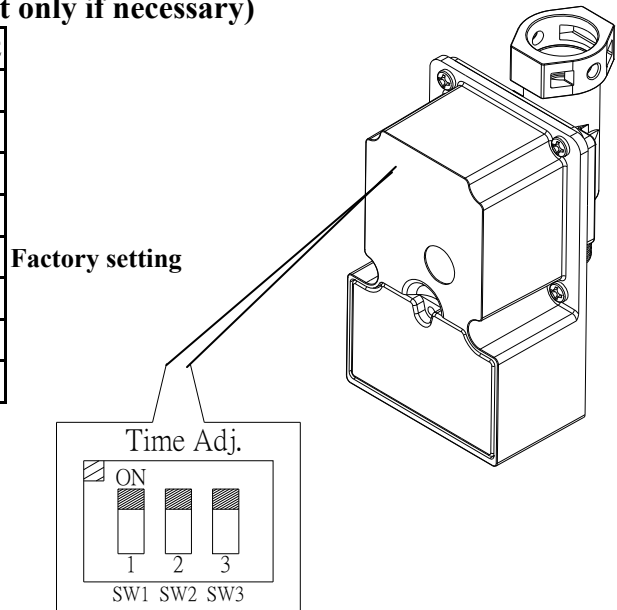

#### ■ Cautions

Prior to installation. Make certain the code on the solenoid valve matches the code on sensor unit. If not, do as follows:

Step1: Find the code matching tool for matching numbers. Press the tool on the specification tag on the solenoid valve for 1 second. Listen for "BEEP".

Step2: Press the manual button within 5 seconds right after step 1. Then the numbers will be automatically reset.

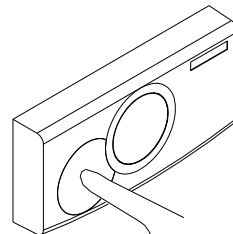
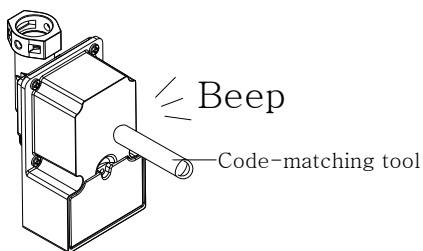

## ■ Troubleshooting

Problem	Cause	Solution to Problem
Light doesn't turn on, The toilet doesn't flush after sensing process	1. No batteries installed in the sensor unit or not installed properly 2. Sensor fails	1. Replace batteries 2. Replace sensor unit
Light flashes on sensor unit	Low battery in the sensor unit	Replace batteries
Light turns on after sensing process, but the toilet doesn't flush	1. Water turned off or filter obstructed 2. The codes of the sensor unit and solenoid valve unit don't match 3. No batteries installed in the solenoid valve unit or installed improperly 4. Solenoid valve fails	1. Turn on the water or clean the filter 2. Reset the codes of sensor unit and solenoid valve.(See P.10 under cautions) 3. Reinstall or replace batteries 4. Replace solenoid valve unit
Solenoid valve continuously beeps	Low batteries in the solenoid valve unit	Replace batteries
Incomplete flushing	1. Filter obstructed 2. Link chain too long(too loose)	1. Clean the filter unit 2. Check to make sure the link chain is adjusted properly
Weak water flow	1. Link chain too long(too loose) 2. Water level too low	1. Check to make sure the link chain is adjusted properly 2. Readjust the tank water level
Water continuously running	1. The water pump lever is stuck or interference is occurring among tank components while operating. 2. Link chain too short(too tight) 3. The solenoid valve fails	1. Check to make sure the water pump is working properly without interference 2. Check to make sure the link chain is adjusted properly 3. Replace solenoid valve unit

## ■ Sensor Unit Mounting – Double-Sided Tape Option

Step1. Wipe both the back of the sensor unit and the wall where the sensor unit will be placed. Be sure both surfaces are clean and dry.



Step2. Peel off the yellow side of the double-sided tape and place it on the back side of the sensor unit as shown in the illustration. Be sure to press firmly while keeping the tape straight. Check to see if the bond is even and secure.



Step3. Peel off tape strips and place the sensor unit on the wall. Be sure to press firmly against the wall.



Please note: If you wait 20 to 30 minutes to attach the sensor unit on the wall, the tape will be more adhesive.

